

Shanghai
Heat Transfer
Equipment



HEAT TRANSFER



www.shphe.com

地 址：上海市金山区山宁路99号 电 话：021-57247555
Add: No.99 Shanning Road, Jinshan, Shanghai
Tel:+86 21 5724 7555 E-mail:shinfo@shphe.com



上海板换机械设备有限公司
Shanghai Heat Transfer Equipment Co.,Ltd.

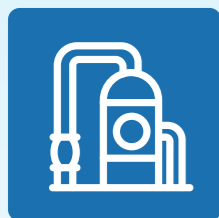

1

Shanghai
Heat Transfer
Equipment

2

Shanghai
Heat Transfer
Equipment

3

Shanghai
Heat Transfer
Equipment

4

Shanghai
Heat Transfer
Equipment

5

Shanghai
Heat Transfer
Equipment

6

Shanghai
Heat Transfer
Equipment

一、企业介绍	04-13
二、企业资质	14-15
三、产品介绍	16-17

Company Profile
Qualification
Product Introduction

可拆卸板式热交换器	18-21
宽通道焊接式 板式热交换器	24-27

Plate & Frame Heat Exchanger
Wide-Gap Welded
Plate Heat Exchanger

TP混合板式换热器	28-29
板式空气预热器	30-33
板框式热交换器	34-35

TP Plate Heat Exchanger
Plate Type Air Preheater
HT-Bloc

印刷电路板式热交换器	36-37
半焊式板式热交换器	38-39
热交换机组	40-41

Printed Circuit Heat Exchanger
Semi-welded Heat Exchanger
Substation Unit

四、上海板换远程 服务平台	42-45
------------------	-------

Remote Service Platform

五、部分业绩	46-47
六、服务宗旨	48-49

Our Customers
Service Objective

CONTENT

Company Profile

企业介绍



上海板换机械设备有限公司是专业从事板式热交换器及其成套装置设计、制造、安装和服务的技术型企业。公司拥有先进的设计和生产技术、全面的热交换器专业知识和丰富的服务经验，一直以来致力于为全球多个国家和地区的石油天然气行业、船舶行业、暖通空调行业、化工行业、食品医药行业、电力行业、生物能源行业、冶金行业、机械制造行业、造纸行业、钢铁行业等的客户提供高品质的板式热交换器。

Shanghai Heat Transfer Equipment Co., Ltd. (SHPHE in short) is an enterprise specialized in design, manufacturing, installation and service of plate heat exchanger and other complete skid equipment.

With cutting-edge engineering and manufacturing technology, comprehensive heat exchanger expertise and rich service experiences, SHPHE dedicates to supply quality plate heat exchangers to clients worldwide in oil & gas, marine, HVAC, chemical, food and pharmacy, power plant, bio-energy, metallurgy, mechanical manufacturing, pulp & paper, steel, etc.

近年来，公司建立“两化融合管理体系”，借助云计算、大数据和互联网等数字技术驱动，以“制造+服务”为核心，搭建满足用户需求的数字服务平台，成功实现智慧传热系统整体解决方案，使用户运维更加安全、高效和智能。依托公司自主研发团队，形成了“提升能源效率”的节能高效核心技术，并成功开发多款符合国家一级能效指标的大型板式热交换器，成为助力国家双碳事业的践行者。

SHPHE has established "Integration of Informatization and Industrialization Management System". Manufacturing coupled with service being the core business, driven by cloud computing, big data and Internet technology, SHPHE has built digital service platform catering to user's needs, and has successfully realized total solution for intelligent district heating system, making operation and maintenance at client's site more secure, efficient and intelligent. With company's innovation and development team, SHPHE has its core technology of energy saving and high efficiency in "improving energy efficiency", and developed a number of large size plate heat exchanger which meet national level of energy efficiency index, making contribution to reduce carbon emission.

2014



成功研制耐压3.6MPa
高压板式热交换器

Developed high pressure GPHE with 3.6MPa

2022



成功开发耐压 9.6MPa
汽提塔内置板式加热器

Developed inner PHE for stripping tower with pressure 9.6Mpa

2015



国内首家成功开发应用于氧化铝
行业的立式宽通道焊接板式换热器

Developed vertical type wide gap welded plate heat exchanger applied in alumina refinery

2023



成功开发换热面积 7300m²/台
丙烯酸塔顶冷凝器

Developed condenser for crylic acid with surface area 7300m²

2019



国内首家完成海洋石油平台大型
板式热交换器国产化开发项目

Developed big size GPHE used on offshore oil platform

2024



成功研制耐压6.4MPa、耐温410℃
大型BLOC焊接板式热交换器

Successfully developed large-scale HT- Bloc welded plate heat exchanger with pressure 6.4 MPa and temperature 410℃.

2021



耐压2.5MPa，换热面积2400m²/台
高压板式热交换器

Developed GPHE with design pressure 2.5MPa, surface area 2400m²

2025



开发设备故障预警系统，成功应用于
冶金、暖通及油气等行业

Successfully developed fault early warning system, which is applied in metallurgy, HVAC, and oil & gas industries.

公司主要产品包括可拆卸板式热交换器、宽通道全焊接板式热交换器、板框式热交换器、TP混合板式热交换器、板式空气预热器等。2013年成功研发应用于远洋油轮、化学品船存储惰性气体系统用板式除湿装置，首次完成国产化制造；2014年成功研制设计压力3.6MPa高压板式热交换器；2015年国内首家成功开发应用于氧化铝行业的立式宽通道焊接板式热交换器；

SHPHE's main products include Plate & Frame Heat Exchanger, Wide-Gap Welded Plate Heat Exchanger, HT-Bloc Welded Plate Heat Exchanger, TP Welded Plate Heat Exchanger, Plate Air Preheater etc. In 2013, the company developed plate dehumidifier for inert gas generation system for gas carrier and chemical tanker, and passed prototype test in Moss, Norway; In 2014, successfully developed PHE of high design pressure 3.6 MPa; In 2015, the first vertical type wide channel welded plate heat exchanger successfully developed and installed in alumina refinery in China;

2019年国内首家完成海上浮式生产储油装置用大型板式热交换器国产化开发项目；2021年成功开发耐压5MPa，换热面积2400m²/台高压板式热交换器；2022年国内首家设计、制造完成耐压9.6MPa汽提塔内置板式加热器；2024年成功研制耐压6.4MPa /耐温410℃;大型BLOC全焊接板式热交换器；2025年开发设备故障预警系统，成功应用于冶金、暖通及油气等行业。

In 2019, SHPHE delivered large size plate heat exchanger for FPSO; In 2021, SHPHE developed GPHE with high pressure 5MPa, surface area 2400m²; In 2022, manufactured and delivered internal heater of pressure 9.6MPa designed for stripper; In 2023, successfully developed large-scale HT-Bloc welded plate heat exchanger with pressure 6.4 MPa and temperature 410℃; In 2025, successfully developed fault early warning system, which is applied in metallurgy, HVAC, and oil & gas industries.



Shanghai Heat Transfer Equipment





公司拥有质量/环境/职业健康安全管理体系认证、特种设备生产许可（压力容器）、板式热交换器产品安全注册、板式热交换器节能注册、ASME、CCS、CE、BV、ABS、GL、NK等证书。

SHPHE has Quality/Environmental/Occupational Health and Safety Management System Certification, Production License of Special Equipment (Pressure Vessel), Plate Heat Exchanger Product Safety Registration, Plate Heat Exchanger Energy Saving Registration Certificate, ASME, CCS, BV, ABS, GL and other certificates.

并参与了《热交换器能效测试与评价规则》TSG R0010、《可拆卸板式热交换器》NB/T47004.1、《焊接板式热交换器》NB/T 47004.2、《中石化板式热交换器采购技术规范》Q/SHCG0100等国家及行业标准的起草。

The company participated in the drafting of National and Industry Standards such as TSG R0010 "Heat Exchanger Energy Efficiency Test and Evaluation Rules"; NB/T 47004.1-2017 "Plate & Frame Heat Exchanger", NB/T 47004.2-2017 "Welded Plate Heat Exchanger", Q/SHCG 0100 - "Plate Heat Exchanger Procurement Technical Specification of Sinopec".

2009年首次获得上海市“高新技术企业”称号；2014年被评为全国质量和服务诚信优秀企业；2015年、2016年连续两年获得“中国年度板式换热器十大品牌”称号；2021年公司被评为上海市“专精特新”企业、金山区技术中心；2023年被评为国家级“专精特新”企业，奠定了在国内板式换热器行业的领先地位。

In 2009, SHPHE was awarded "Shanghai High-tech Enterprise" for the first time; In 2014, SHPHE was awarded "National Excellent Enterprise" in quality and service integrity; In 2015 and 2016, SHPHE was awarded "Top 10 Brands of Plate Heat Exchanger in China". In 2021, SHPHE has also been awarded honor like "Shanghai Specialized and Created Enterprise", "Jinshan District Technology Center", laying a leading position in the domestic plate heat exchanger industry.



公司立足上海，服务全球，在全球设立多处服务网络，以满足客户需求。产品远销美国、加拿大、马来西亚、印度、伊朗、印尼、希腊、澳大利亚等国家。

Based in Shanghai, SHPHE has service centers around the world to meet customer's needs. Products are exported to US, Canada, Malaysia, India, Iran, Indonesia, Greece, Australia and other countries.



HEAT TRANSFER

Shanghai
Heat Transfer
Equipment



Company Profile

先后为中石油、中石化、中海油、中船重工、中国铝业、中粮集团、魏桥集团、万华化学、信发集团、锦江集团、潍柴动力、东方希望、盛虹集团、中国电投、国投生物、吉林燃料乙醇、上海华谊、中石化绿源地热、兰州热力、郑州热力、开封金盛热力、迈安德集团、三一重工、浙能迈领、中船集团、沪东造船厂等国内企业以及BASF、LANXESS、Kerry、Fluor、Cameron、BP、GS、POSCO、Rio Tinto、Mylilineos、US Steel、Optimus Steel、DTE Energy、CP Kelco、Vedanta、NALCO、Petronas等跨国公司提供了多种类型的热交换设备和相关服务。

The company has supplied various plate heat exchanger to domestic client such as CNPC, Sinopec, CNOOC, CSIC, Aluminum Corporation of China, COFCO, Weiqiao Group, Wanhua Chemical, Xinfu Group, Jinjiang Group, Weichai Power, Eastern Hope, Shenghong Group, Jilin Fuel Ethanol, Shanghai Huayi, Sinopec Green Energy Geothermal, Lanzhou Thermal Power, Zhengzhou Thermal Power, Kaifeng Jinsheng Thermal, Myande, SANY Heavy Industry, ZheJiang Energy Marine, CSSC, Hudong-zhonghua Shipbuilding and transnational companies like BASF, LANXESS, Kerry, Cameron, BP, GS, POSCO, Rio Tinto, Mytilineos, US Steel, DTE Energy, CP Kelco, Vedanta, NALCO, Petronas, etc.

公司坚持以永无止境的技术进步引领行业发展，与国内外优秀企业并肩前行，致力成为热交换领域“国内领先、国际一流”的优质解决方案系统集成商。

With technology leading development of the line, working with high end enterprises, SHPHE is aiming to be a solution provider in plate heat exchanger industry.

Qualification

企业资质



ASME

CE

NB

ABS



CCS

BV

ISO9001:2015

ISO45001:2018



ISO14001:2015

节能注册证

两化融合

石化行业百佳供应商



高新技术企业



产品安全注册证

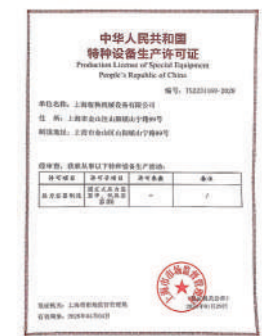

特种设备生产许可证



知识产权管理体系认证



计算机软件著作权



软件产品证书



专利证书 (部分)

PRODUCT

INTRODUCTION

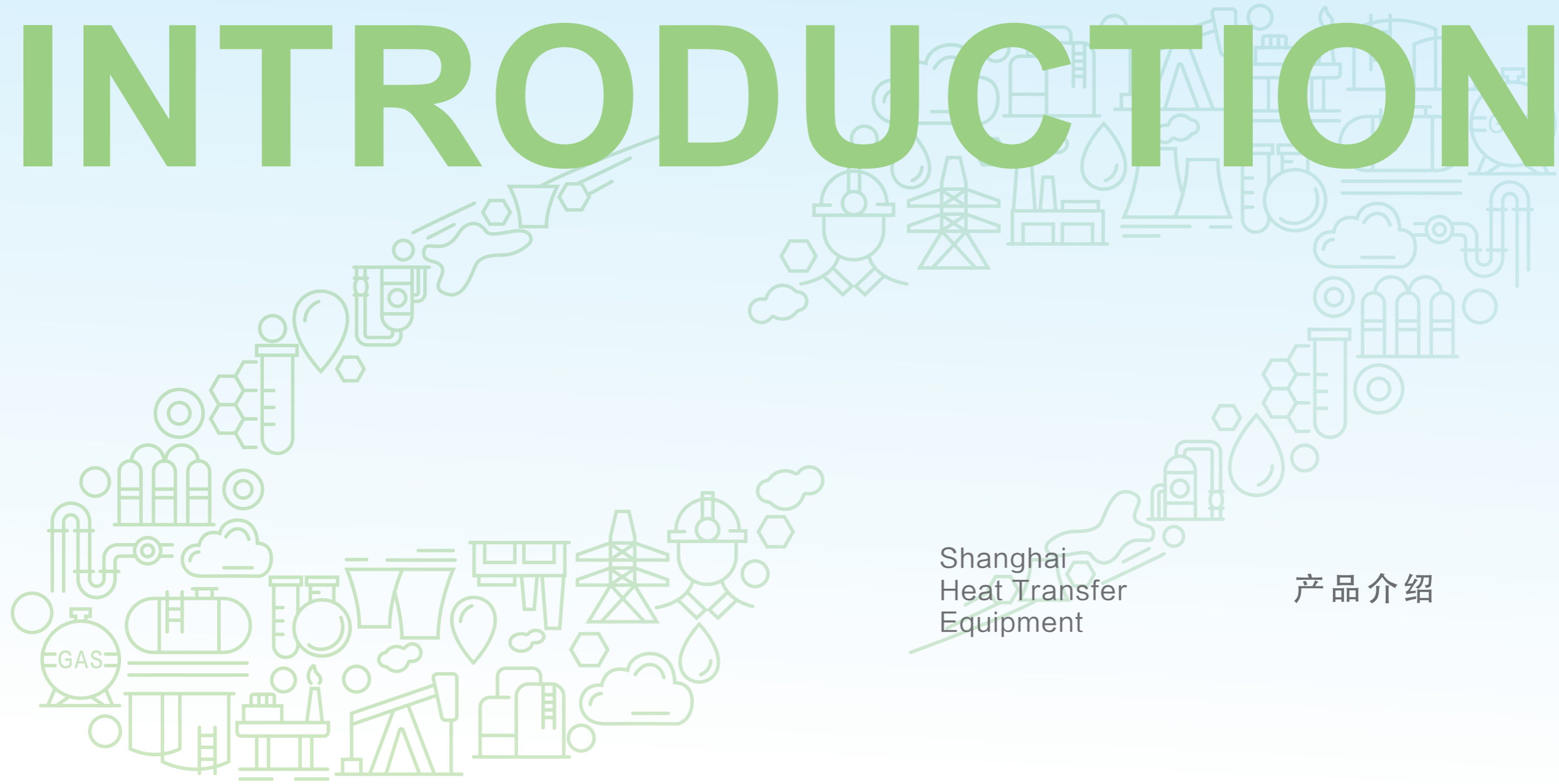

Shanghai
Heat Transfer
Equipment

产品介绍

Plate & Frame Heat Exchanger

可拆卸板式热交换器



Shanghai
Heat Transfer
Equipment

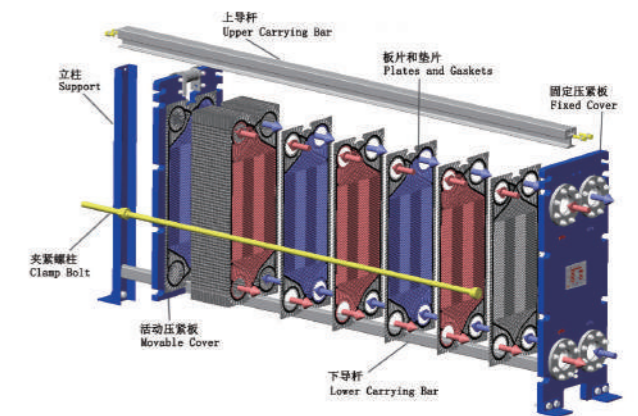

HEAT TRANSFER

可拆卸板式热交换器是由许多冲压有波纹槽的金属热交换板片，按一定间隔交替放置，每张板片都有垫片密封，并用夹紧螺柱压紧在框架内而成，其角上的孔构成了连续的通道，介质从入口进入通道，被分配到热交换板片之间的流道内，两种介质在通道内逆流流动，冷热侧的热量通过热交换板片进行传递，从而达到热介质温度降低被冷却，冷介质温度升高得到加热的目的。具有传热系数高、污垢系数低，结构紧凑、占地空间小，检修、清洗方便，末端温差小，重量轻等特点。

Plate & frame heat exchanger is composed of heat transfer plates (corrugated metal plates) which are sealed by gaskets, tightened together by tie rods with locking nuts between frame plate. The port holes on the plate form flow channel, the fluid runs into the channel from inlet and is distributed into flow channel between heat transfer plates. The two fluids flow in counter current. Heat is transferred from hot side to cold side through heat transfer plates, the hot fluid is cooled down and the cold fluid is warmed up. The main features of Plate & frame heat exchanger: high HTC, low fouling resistance, compact structure with small footprint, easy maintenance and cleaning, small end approach temperature, light weight, etc.

Shanghai Heat Transfer Equipment

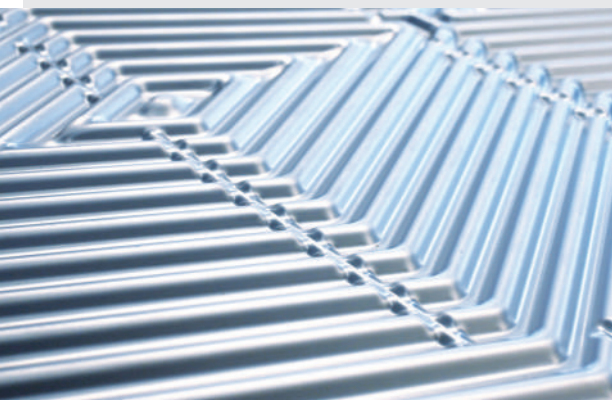
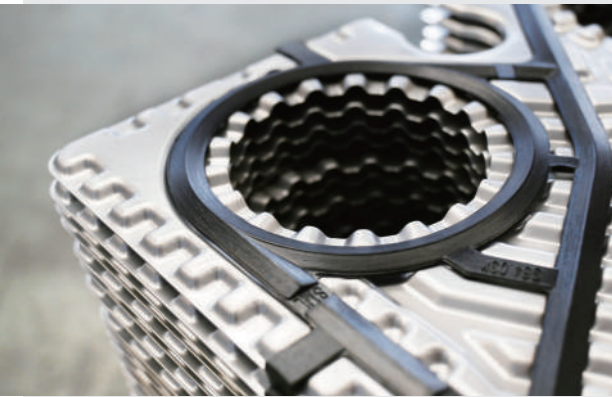

产品特点	Features
传热系数高	High heat transfer coefficient
结构紧凑、占地空间小	Compact structure with less foot print
检修、清洗方便	Convenient for maintenance and cleaning
污垢系数低	Low fouling factor
末端温差小	Small end-approach temperature
重量轻	Light weight

板片材料	Plate Material
奥氏体不锈钢	Austenitic stainless steel
双相不锈钢	Duplex steel
钛及钛合金	Titanium and titanium alloy
镍及镍合金	Nickel and nickel alloy

基本参数	Parameter
角孔直径: DN32 ~ DN500 (接管连接形式有法兰连接、螺纹连接)	Nominal dia: DN32~DN500 (with flanged nozzle or studded connection)
板片厚度: 0.4 ~ 1.0mm	Plate thickness: 0.4~1.0mm
波纹深度: 1.8 ~ 10.0mm (适用于清洁、低粘介质、含有纤维、粘稠、固体颗粒介质等工艺条件)	Profile depth: 1.8~10.0mm (suitable for clean, low viscosity medium and process containing fiber, viscous and solid particles)
最高设计压力: 3.6MPa	Max. design pressure: 3.6MPa
最高设计温度: 180℃	Max. design temp: 180 °C
最大组装面积: 4000 m ²	Max. surface area: 4000m ²

密封垫材料	Gasket Material
丁腈 (食品) 橡胶	NBR (NS)
氯化丁腈橡胶	HNBR
三元乙丙 (食品) 橡胶	EPDM (ES)
耐高温三元乙丙橡胶	H-EPDM
氟橡胶	FKM
聚四氟乙烯包覆橡胶	PTFE CUSHION



热交换板片是板式热交换器的核心元件，运用CAD/CFD/CAE/CAM等三维软件设计板片模具，在板片的研发及综合技术上进行优化，达到结构合理、换热效率高、精度高、承压能力大等特点。

Heat transfer plate is the core element of plate heat exchanger. The plate tool is designed with CAD/CFD/CAM and optimized to achieve best configuration, high heat transfer efficiency, high precision and high pressure resistance.

DUPLATE® 板片

双相不锈钢
DUPLATE®板片
适用于高温、高压
苛刻工况使用



DUPLATE® (in duplex stainless steel) is suitable for critical process with high pressure, high temperature.

密封加强边™

独特的密封加强边™结构设计，确保板片具有可靠的耐高压密封性能

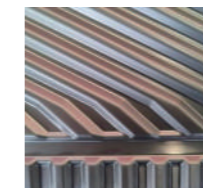

The design with reinforced sealing edge of the plate enhanced sealing performance of the plate at high pressure.

回型双面扣™

独特回型双面扣™结构，使板片与胶垫的连接更为可靠



The double clip gasket design makes the fixing between plate and gasket more reliable.

板片密封专有技术

板片采用熊猫眼™设计结构，降低阻力损失，提升流体流通能力及传热效率

The design with Panda Eye of the plate reduced pressure loss, fluid flowing capacity and heat transfer efficiency get enhanced.



Shanghai
Heat Transfer
Equipment

HEAT TRANSFER



Wide-Gap Welded Plate Heat Exchanger

宽通道焊接板式热交换器

宽通道焊接板式热交换器有窝状和柱状两种板片形式，板片之间形成介质流道，周边通过焊接密封，替代了可拆卸板式热交换器的橡胶垫密封结构，适用于制糖、造纸、冶金、酒精、石油、化工等行业生产工艺中处理含有大量固体颗粒、纤维悬浮物，以及粘稠状或高温流体的加热或冷却。由于热交换板片结构的特殊设计，使传热效率及压降损失优于同工况条件下其它形式的热交换设备，宽间隙流道内流体流动顺畅、无滞留、无死区，可有效防止流道堵塞，减缓磨蚀现象发生。

There are two plate patterns for wide-gap welded plate heat exchanger, are. dimple pattern and studded flat pattern. Flow channel is formed between the plates sealed by welding. Wide-Gap Welded Plate Heat Exchanger is suitable for heating or cooling process in sugar mill, pulp & paper, metallurgy, ethanol, petro-chemical and other industries where fluid containing solid particles, fiber suspensions or viscous fluid. WGPHE surpass other type of exchangers in the same process in high heat transfer efficiency and low pressure drop. The fluid flowing in the exchanger smoothly without clogging.

Structure of plate pack

芯体形式

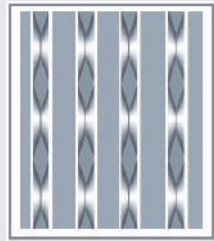
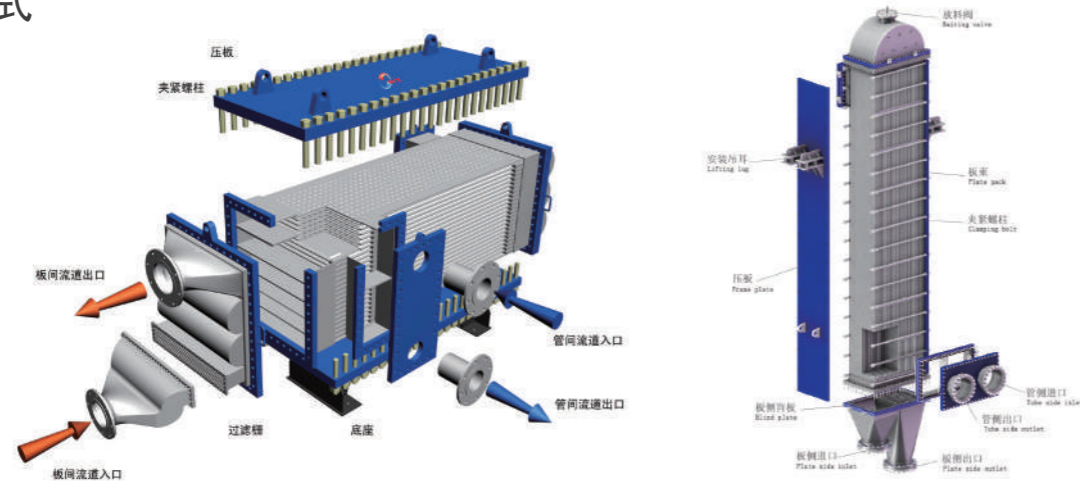

一侧流道为窝状波纹板形成触点，并在触点部位点焊的通道，较干净的介质流经此通道；另一侧流道为窝状波纹板形成宽间隙、无触点的通道，含有固体颗粒或高粘度的介质流经此通道。

The channel at one side is formed by spot-welded contact points between dimple-corrugated plates. Clean medium runs in this channel. The channel at the other side is wide gap channel formed between dimple-corrugated plates without contact points, viscous medium or medium containing coarse particles runs in this channel.

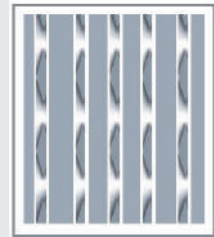

一侧流道为窝状波纹板与平板之间形成触点，并在触点部位点焊的通道，较干净的介质流经此通道；另一侧流道为窝状波纹板与平板之间形成宽间隙、无触点的通道，含有固体颗粒或高粘度的介质流经此通道。

The channel at one side is formed by spot-welded contact points that are connected between dimple-corrugated plate and flat plate. Clean medium runs in this channel. The channel at the other side is formed between dimple-corrugated plate and flat plate with wide gap and no contact point. The medium containing coarse particles or viscous medium runs in this channel.

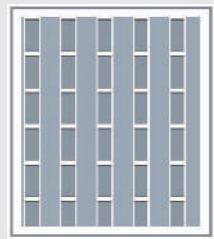

一侧流道为平板与平板之间焊接有圆形定距柱形成触点；另一侧流道为平板与平板之间形成宽间隙、无触点的通道，两种通道都适合含有固体颗粒、纤维或高粘度的介质流过。

The channel at one side is formed between flat plate and flat plate welded together with studs in between. The channel at the other side is formed between two flat plates without contact point. Both channels are suitable for viscous medium or medium containing coarse particles and fiber.



Features 产品特点

板片形式:	窝状、柱状	Plate pattern:	Dimple, studded flat plate
设计压力:	真空~3.5MPa	Design pressure:	Vacuum~3.5MPa
板片厚度:	1.0~2.5mm	Plate thickness:	1.0~2.5mm
设计温度:	≤350℃	Design Temp:	≤350℃
流道间距:	8~30mm	Channel gap:	8~30mm
最大组装面积:	2000 m ²	Max. surface area:	2000m ²



TP Plate Heat Exchanger

TP混合板式热交换器

板束间采用先进的自动焊机焊接，全部板束焊接在壳体内，可以将壳体打开进行机械清洗流道，特殊的流道结构保证介质之间不会串液和外漏，既具有板式热交换器的高效传热和结构紧凑的优点，又具有管壳式换热器耐高压、高温的特性，是一些特殊热交换工艺中替代管壳式换热器的最理想设备。已广泛应用于石油化工、电力、冶金、暖通空调、食品医药等行业。

The plate pack is welded together with automatic welding machine, and welded within a housing which could be opened for mechanical cleaning. The unique designed channel configuration ensures no mixture or leakage of two fluids. Fully welded plate heat exchanger has the advantages of high heat transfer efficiency and compact structure of plate & frame heat exchanger, coupled with characteristics of high pressure and high temperature resistance of tubular heat exchanger, making it possible to replace tubular heat exchanger in some process. Fully welded plate heat exchangers are widely used in petrochemical, power plant, metallurgy, HVAC, food and pharmacy industry.

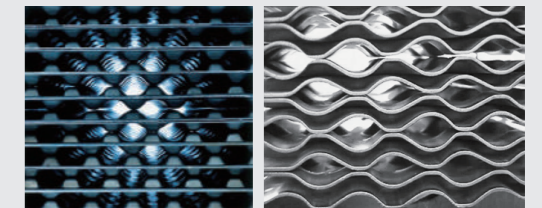

流道形式

Channel form

Technical parameters

技术参数

设计温度：-196℃~900℃
设计压力：真空~6.0MPa
组装面积：≤15000m²
板片厚度：0.6~1.5mm

Design temp: -196℃ ~ 900℃
Design pressure: vacuum ~ 6.0MPa
Surface area: ≤15000m²
Plate thickness: 0.6~1.5mm

Plate Type Air Preheater

板式空气预热器



CHEMICAL

板式空气预热器是一种节能环保设备，使用平板或波纹板，板片周边通过焊接或机械固定形成板束，整机采用积木式设计，组合方式灵活多变，结构适应性强，特有的空气膜™技术能够有效解决露点腐蚀问题，适用于炼油、化工、钢铁、冶金、电力工业等行业。



STEEL MILL

Plate air pre-heater is energy saving and environmental friendly equipment. The main heat transfer element, ie. flat plates or corrugated plates are welded together to form plate pack. The modular design of the product makes the structure flexible. AIR FILM™ technology provides solution for dew point corrosion. Air preheater is widely used in oil refinery, chemical, steel mill, power plant, etc.

模块化设计理念

具有X型、E型、C型及S型四种基本的换热模块单元，分模块制造，便于运输、现场组装

Modular design

4 different base heat transfer modules available, ie. X brick, E brick, C brick and S brick, making it easy to transport and assemble on site for big size product.

积木式分段设计

可实现模块化、组合化、大型化，空间尺寸调节灵活

The brick combination design

All the base modules can be combined in large scale. Both manufacture process and equipment size turn to be flexible for adjustment.

不易积灰、清洗、维修便捷

换热流道内无死区，不易积灰，即便积灰也便于清洗，且可做到在线清洗

free from dust gathering; convenient for cleaning and maintenance

No dead flowing area in flow channel, free from dust build-up.

换热效率高，热量回收充分

烟气出口处换热板温度设计在酸露点5-10℃以上即可安全运行

消除热应力

通过模块化、弹性化、分段分体、补偿器设计等措施解决热应力问题

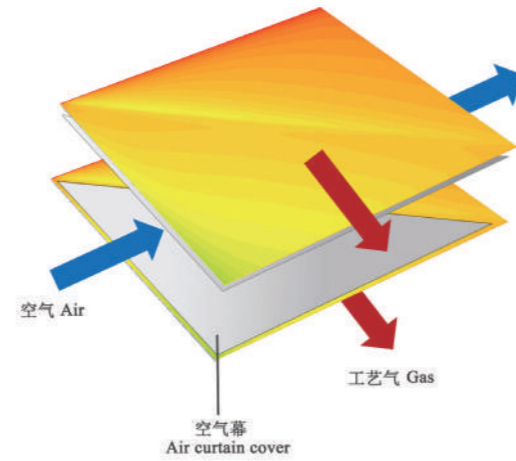
**防露点腐蚀**

利用科学的流程布置、特有的空气膜™技术、旁路调节及耐腐蚀材料等方式，防止露点腐蚀

Acid dew point corrosion prevention

Acid dew point corrosion can be prevented or reduced by adjusting pass configuration, AIR FILM technology, by-passing control and corrosion resistant materials.

High heat transfer efficiency, good heat recovery

By setting the outlet gas temp. 5-10℃ above the acid dew point, the equipment can be operated safely.

Relieving thermal stress

multiple measurements to resolve thermal stress, eg. multi-temperature grade method, expansion joints, etc.

传热性能高、压降低

板式换热元件的传热系数比管式换热元件高1~3倍，且可根据冷、热介质换热前后的体积变化，采用流道间距与流动长度的优化组合，实现传热性能与压降的最优化设计

安全可靠

热交换板片采用全焊接结构，密封性能好，可避免介质的泄漏

Safe and robust

Fully welded plate structure proved good sealing performance, avoiding leakage of the medium.

适用范围广，节能环保

适用于多种位号的常压（低压）气-气换热工况

Wide range of application, energy-saving and environmental protection

Suitable for various gas-gas heat exchange process (atmospheric or low press.)

Plate Type Air Preheater

Higher heat transfer performance and lower pressure drop

HTC of plate type is 1~3 times of tubular type air pre-heater. According to volume change of cold/hot medium before /after heat exchange, it can achieve optimal design of heat transfer and pressure drop by combining channel gap and flowing length.

耐腐蚀性能好，经济耐用

对不同介质、工况可针对性的选择适用材料，从而保证设备寿命，而且可采用高低温分级设计，不同温度段可使用不同材料，有效降低制造成本

better anti-corrosion performance economic and robust

Different material is used for different medium/process to ensure equipment's service life.

结构紧凑，节约空间

单位体积能提供更大的换热面积

Compact structure

More heat transfer area per unit volume.

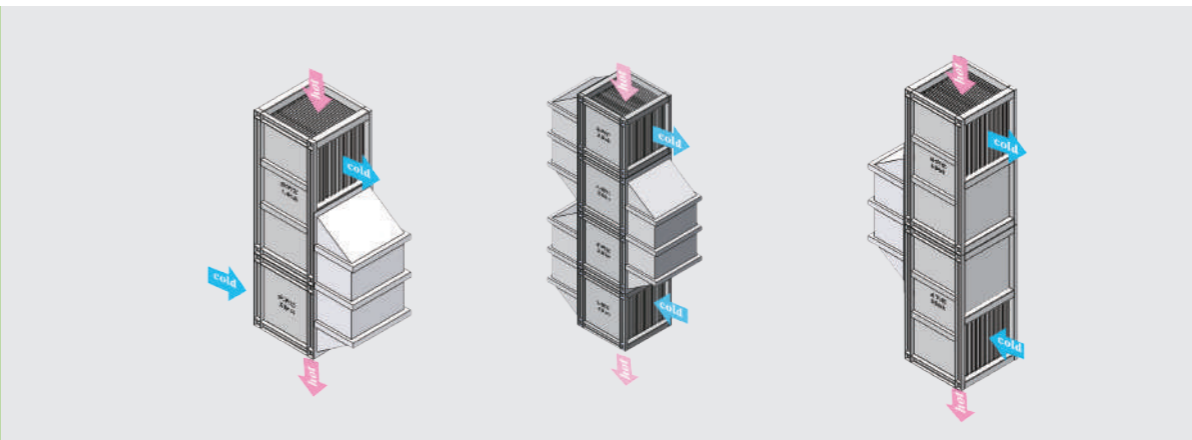
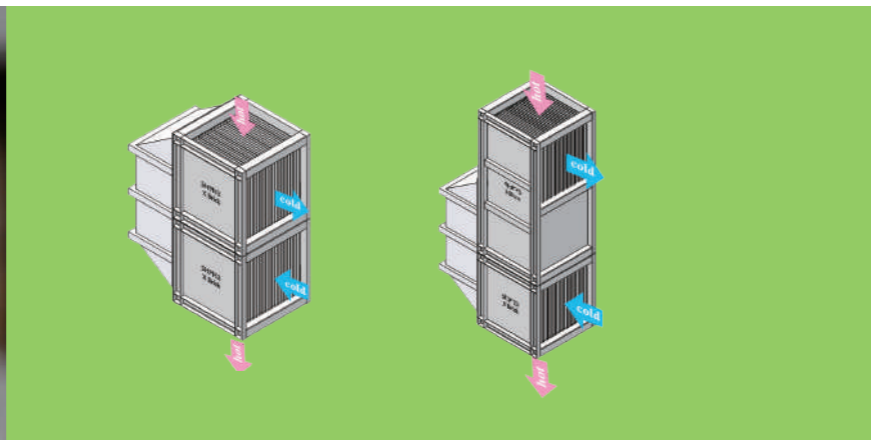

Shanghai
Heat Transfer
Equipment

HT-Bloc

板框式热交换器

一种既保持了传统板式热交换器传热效率高又具备普通管壳换热器在更高的温度和压力下使用的，可靠性高的焊接板式热交换器。在炼油、石化、化工、电力、冶金、制冷等行业，得到广泛应用。

HT-Bloc is a kind of welded plate heat exchanger with high heat transfer efficiency under high temp. and high pressure process. It is widely applied in oil refinery, petrochemical, chemical, power plant, metallurgy, refrigeration and other industries.

Features

产品特点

传热效率是传统管壳式换热器的3-5倍；面对两侧介质流量比较大的工艺条件，也能得到良好的换热效率；灵活的流程设计，在提高流体湍流程度的同时，板片表面产生较大的壁面剪切力，有效延长设备结垢清洗周期。

The heat transfer efficiency of HT-Bloc is 3-5 times of shell & tube heat exchanger. Satisfactory heat transfer performance can be achieved for process with higher flow ratio between two fluids. Flexible pass design not only enhances flowing turbulence, but also generates large wall shear force on plate surface, extending cleaning cycle of the equipment.

板束板间采用对接焊结构，避免缝隙腐蚀的发生；两侧可拆卸结构，便于清洗维护；结构紧凑，占地空间小。

Butt welding between plate pairs reduce the risk of crevice corrosion; Openable structure of frame plate make it easy for cleaning and maintenance.

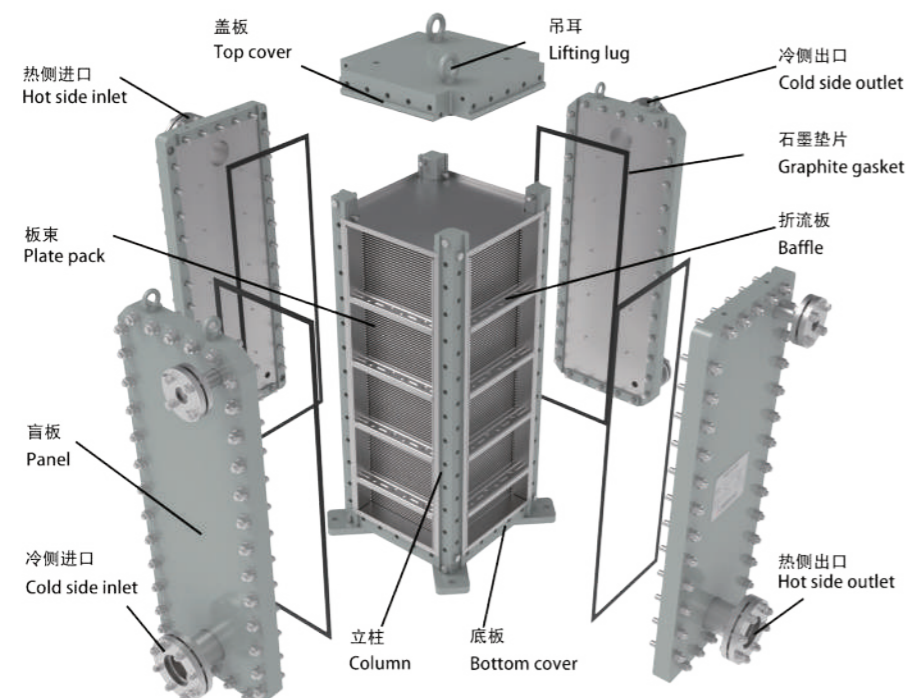

Basic Parameters

基本参数

板片形式：波纹板、柱状板、窝状板
 设计温度：-50~400℃
 设计压力：真空~4.0MPa
 换热面积：1~870m²
 公称直径：DN 25 ~ DN1000
 板片厚度：0.8~2.0mm
 板片材质：奥氏体不锈钢，双相不锈钢
 254SMO，钛及钛合金，镍及镍合金
 哈氏合金

Plate pattern: Chevron, Dimple, studded flat
 Design Temp: -50~400℃
 Design pressure: Vacuum~4.0MPa
 Surface area: 1~870m²
 Nominal dia.: DN25~DN1000
 Plate thickness: 0.8~2.0mm
 Plate material: austenitic steel, duplex steel,
 254SMO, Ti and Ti alloy, Ni and Ni alloy.

Printed Circuit Heat Exchanger

印刷电路板式热交换器

一种高效紧凑的微通道焊接板式热交换器，采用金属板片作为主要换热元件。金属板片通过化学蚀刻形成介质流道，并将板片堆叠通过扩散焊接形成换热芯体。换热芯体与壳体、封头、接管等零部件装配焊接形成热交换器。印刷电路板式热交换器适用于核能、船舶、石油石化、航空航天、电力、新能源等行业，尤其在对换热效率和空间利用有严格要求的场合下表现突出。

Printed Circuit Heat Exchanger (PCHE) is a high efficiency micro channel heat exchanger with extremely compact structure. The heat transfer element is thin plate of different metal, being chemically etched, micro channels are formed. Heat exchanger core is formed by incorporating diffusion bonding (a specialized solid-state joining process) of the stacked plates, assembled with other components like housing, header, nozzles, flanges, etc., complete heat exchanger is made. PCHE has advanced thermal performance in applications where there is demanding requirement for thermal efficiency, space, eg. nuclear energy, marine, Oil & Gas, aerospace, power, new energy.

Features

产品特点

- 传热系数高
- 承压能力高
- 耐温能力强
- 末端温差小
- 重量轻
- 结构紧凑，占地空间小

- High HTC
- High pressure resistance
- Wide temp. range
- Close temp. approach
- Light weight
- Compact structure with small foot print.

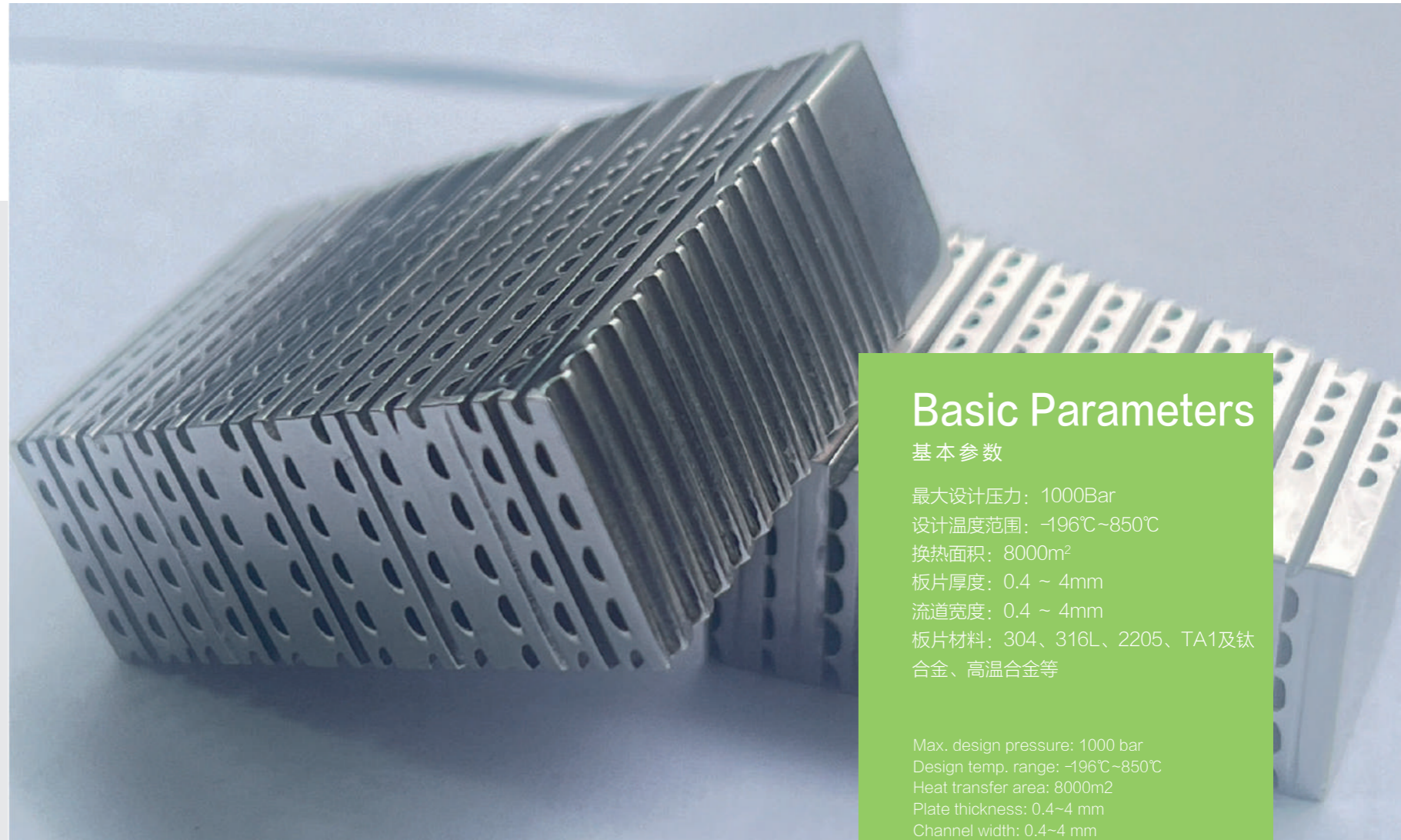

Basic Parameters

基本参数

- 最大设计压力: 1000Bar
- 设计温度范围: -196℃~850℃
- 换热面积: 8000m²
- 板片厚度: 0.4 ~ 4mm
- 流道宽度: 0.4 ~ 4mm
- 板片材料: 304、316L、2205、TA1及钛合金、高温合金等

- Max. design pressure: 1000 bar
- Design temp. range: -196℃~850℃
- Heat transfer area: 8000m²
- Plate thickness: 0.4~4 mm
- Channel width: 0.4~4 mm
- Plate material: 304, 316L, duplex steel, Ti, Ti alloy, high-temp. alloy

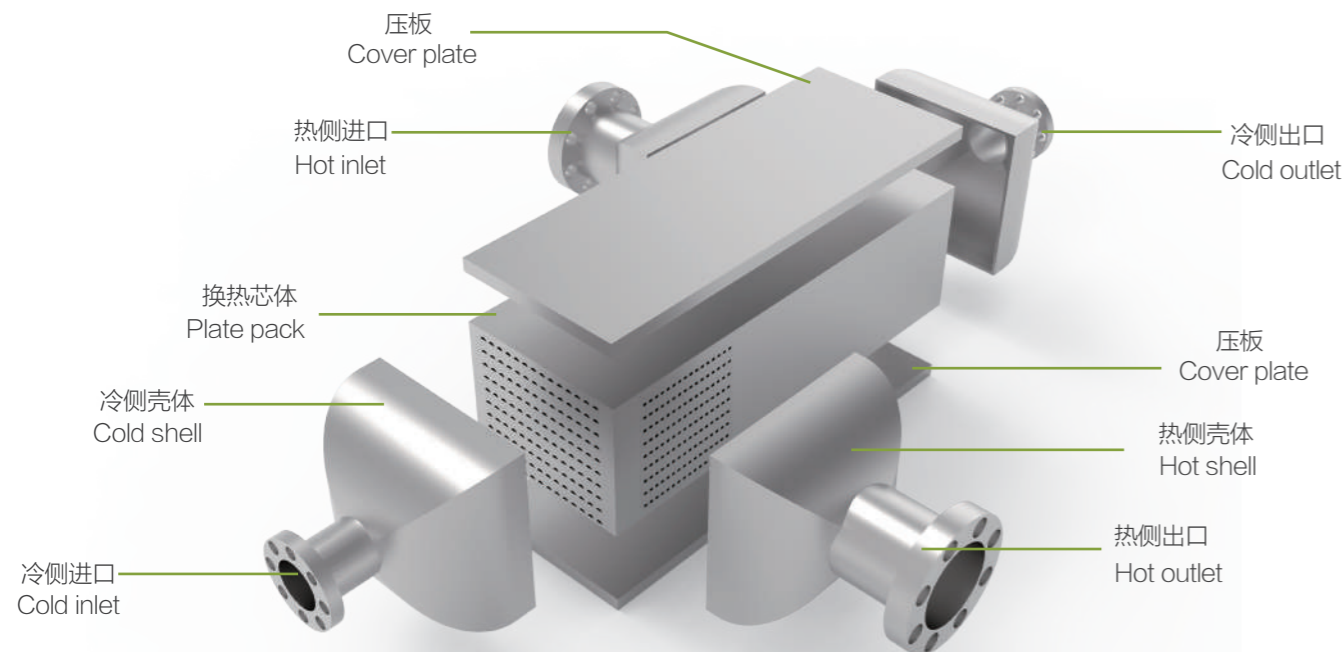
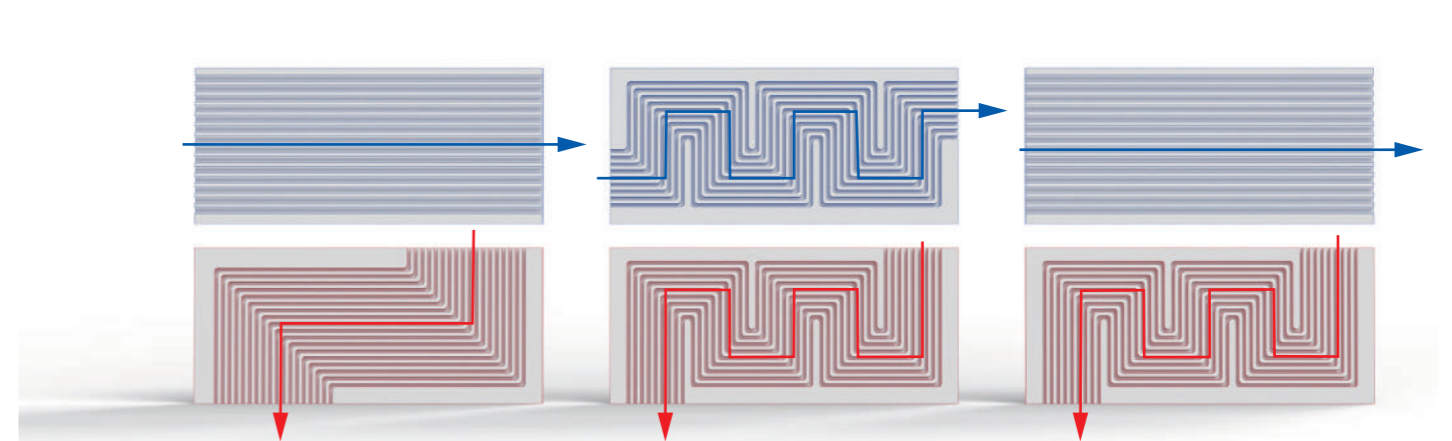

Plate 板片设计

根据不同的工艺条件，可定制不同波纹形式的板片，形成独特的流动方式，满足不同工况需求。

Plate with different corrugation pattern can be custom made to suit different process need with unique flowing path.





Semi-welded Heat Exchanger

半焊式板式热交换器

半焊式板式热交换器由激光焊接流道和常规流道交替组成，两张板片焊接而成板片组，形成焊接流道；每一板片组之间采用密封垫密封，形成可拆的常规流道。敏感性介质流经焊接流道，常规介质流经常规流道进行换热。适用于氨和氟利昂等制冷剂的蒸发和冷凝，对于化工和一般工艺热交换中对垫片会产生腐蚀的介质亦是理想的热交换设备。

Plate channels of semi-welded plate heat exchanger are composed of laser-welded channel and gasketed channel in alternate assembly. Two plates are laser welded together to form a cassette which is welded channel. Gasketed channel is formed between two cassettes sealed by gasket. Aggressive fluid goes through welded channel and the other medium goes through gasketed channel. It is applied in evaporation or condensation process such as ammonia, refrigerant. For chemical process in which the fluid is not compatible with normal gasket, semi-welded plate heat exchanger can be the solution.

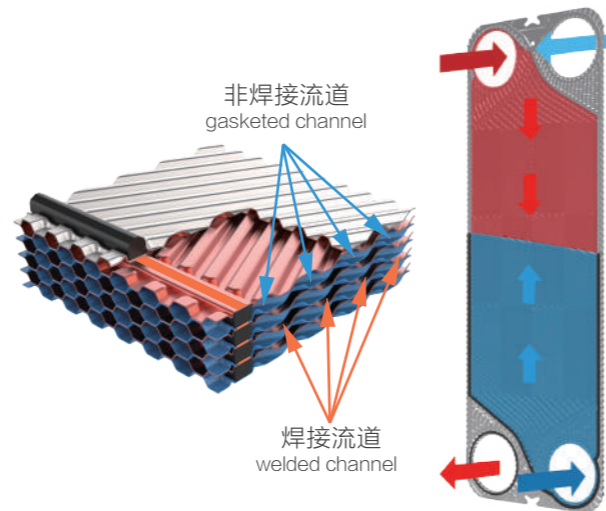

Unique flow channel

独特的流道设计

独特的流道设计可以增加介质流经板式换热器时的紊流强度，增强换热效果并减少相应的压力损失。即使介质在换热器内的流速很低，亦可得到很高的换热效率，为了满足不同工况的要求，有多种板型可供选择。

The unique designed flow channel increases flowing turbulence when the media flowing through the channel, enhancing heat transfer efficiency and minimizing pressure drop. Excellent heat transfer performance can be achieved even with moderate low flow rate. Variety of plate model are available for different application need.

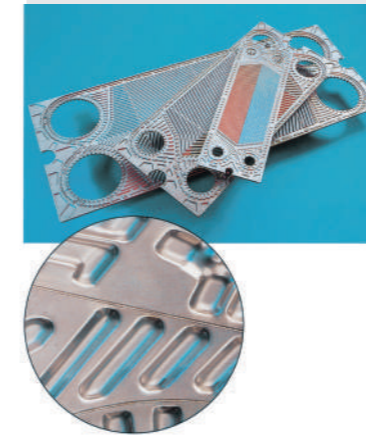

基本参数

角孔直径：DN50~DN300(连接形式有金属衬环、接管法兰)
板片厚度：0.6~0.8mm
板片深度：2.5~4.1mm
最高设计压力：4.0MPa
最高设计温度：180℃
最大组装面积：1200m²

Parameter

Nominal dia: DN50~DN300(with flanged nozzle or studded connection)
Plate thickness: 0.6~0.8mm
Profile depth: 2.5~4.1mm
Max. design pressure: 4.0MPa
Max. design temp: 180 °C
Max. surface area: 1200m²

板片材料

SUS 304
SUS 316L
254SMO
C-276
TA1

Plate Material

SUS 304
SUS 316L
254SMO
C-276
TA1

密封垫材料

三元乙丙
丁腈橡胶
氯化丁腈橡胶
Viton

Gasket Material

EPDM
NBR
HNBR
Viton

Plate Coil

压焊板换热器

压焊板换热器(热辐射板组)是将两张成形板片采用电阻焊接(点焊和缝焊)形成介质通道。产品结构根据工艺要求可以加工成需要的形状，广泛应用于干燥、油脂、化工、石化、食品医药、暖通空调等行业。

板片材料：碳钢、奥氏体不锈钢、双相不锈钢、镍基合金、钛合金等。

The channel of plate coil is formed by welding two plates together by laser welding/resistance welding. Plate coils can be in variety of configuration according to process requirement. It is widely used in drying, grease, chemical, petrochemical, food and pharmacy, HVAC, etc.

Plate material: Carbon steel, austenitic steel, duplex steel, Ni and Ni alloy, Ti and Ti alloy, etc.

Features

产品特点

可以准确控制传热介质的循环温度和速度；便于清洗、更换、维护；结构灵活、板片材料多样化，适用范围广；传热效率高，在有限的容积内，可以提供较多的传热面积。

Fluid temp. and velocity can be well controlled; Convenient for cleaning, replacement and repair; Flexible structure, variety of plate material, wide application; High thermal efficiency, more heat transfer area within small volume.





Substation Unit

热交换机组

热交换机组是集成了板式热交换器、水泵、阀门、仪表及控制系统于一体的热交换成套设备，可根据用户需要配置传感器、控制器、执行机构、远程通讯等控制系统，以实现不同的控制功能。热交换机组适用于汽-水热交换、水-水热交换、油-水热交换等工作条件，已广泛应用于暖通空调、石化、船舶等行业。

Substation unit is skid mounted equipment integrated with plate heat exchanger, pump, valve, instrumentation and control system. Other accessories like sensors, controller, actuators and remote communication control system can be integrated according to customer's requirements to realize different control function.

Substation units are used in process like steam-water, water-water, and oil-water application. It is widely used in HVAC, petrochemical and marine, etc.



Control Function

控制功能

恒温或恒温差、恒压或恒压差供水；气候补偿（温度补偿）；循环泵/补水泵变频调速；来电自启动；泵阀连锁；自动补水定压；超温、超压报警/各种故障报警；各种保护功能；数据采集、通讯，远程控制。

Water supply with constant temp. or constant pressure; Temp. compensation;
Circulating pump/makeup water pump frequency control; Self-startup upon power resume; Interlock between pump and valve; Automatic water makeup and pressurization; Fault alarm, eg. temp. and pressure limit exceeded; Different protection function; Data collection, communication, remote control.

Features

产品特点

设计简便，提高工作效率；结构紧凑，占地空间小，节省基建投资；智能化、自动化程度高，可实现远程和就地控制，便于集中管理；先进的设计理念，更注重环保、节能；生活水机组采用独特的设计，在恒温供水的前提下，最大限度地防止水垢的形成，保证系统高效运行；模块化设计，灵活选择，管路控制管理方便。

Smart design improved work efficiency; Compact structure with less foot print, infrastructure cost saving; Both remote and on-site control can be realized upon request; cutting edge design concept, environment friendly and energy saving; Unique design for domestic hot water unit, with constant water temp, preventing fouling at maximum to ensure efficient operation of the system; Modular design with flexible selection, convenient management of piping.

Remote service platform

上海板换远程服务平台

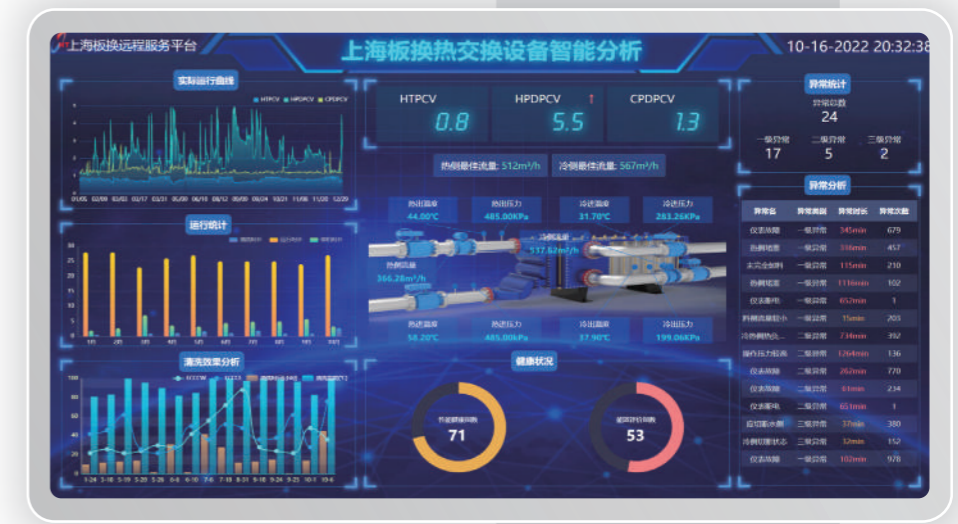

平台介绍

上海板换远程服务平台利用先进的互联网、物联网、人工智能、大数据、云计算等技术，凭借多年来在各个行业中积累的基础物性数据库、运行大数据，结合热源、管网、热交换器、智能阀门、仪表等设备，将综合影响双碳指标的各项数据，科学的分析计算、合理的平衡调度，使得系统处于安全运行、耗能最低状态。

Remote Service Platform developed by SHPHE integrated Internet, IoT, AI, big data, cloud computing technology, coupled with physical properties, operating data in different process over the years, and taking consideration of heat source, pipe networks, heat exchangers, intelligent valves, instruments, etc., the platform can analyze and calculate the data and propose best practice instruction, enabling the system in a safe operation with min. energy consumption.

技术及应用

上海板换远程服务平台在城市供热领域拥有两项核心算法模型，一是基于气象数据、室内反馈、站内反馈数据研发一套能够在保障室内温度的前提下自主调节、能耗最低的自适应算法模型；二是能够对关键零部件进行故障预警，运行过程中在偏离最佳运行工况或核心元件需要更换时提醒运维人员，在威胁运行安全时，系统自动发出保护指令，防止事故发生。

There are two algorithm for city district heating system in the service platform, one is a set of self-adaptive algorithm model which can automatically adjust and minimize energy consumption while ensuring indoor temperature based on meteorological data, indoor feedback and station feedback data. Another is to provide fault warning for key equipment, and reminding operator when deviation from optimal operating conditions occurs or main components need to be replaced.

Remote service platform

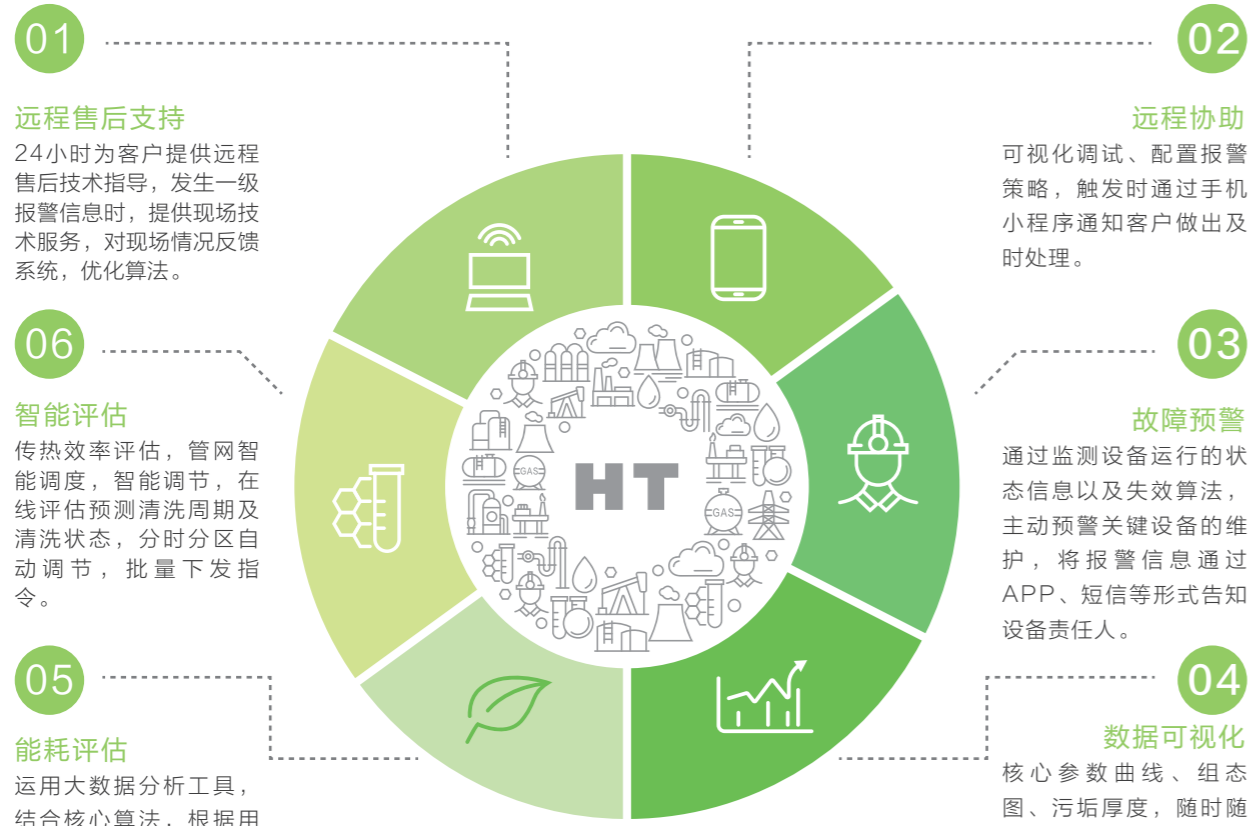

01 远程售后支持
24小时为客户提供远程售后技术指导，发生一级报警信息时，提供现场技术服务，对现场情况反馈系统，优化算法。

02 远程协助
可视化调试、配置报警策略，触发时通过手机小程序通知客户做出及时处理。

06 智能评估
传热效率评估，管网智能调度，智能调节，在线评估预测清洗周期及清洗状态，分时分区自动调节，批量下发指令。

03 故障预警
通过监测设备运行的状态信息以及失效算法，主动预警关键设备的维护，将报警信息通过APP、短信等形式告知设备责任人。

05 能耗评估
运用大数据分析工具，结合核心算法，根据用户个性化需求定制报表，建立能源指标，加强对能源绩效的改进。

04 数据可视化
核心参数曲线、组态图、污垢厚度，随时随地了解设备运行状态。

Remote After-Sales Support 01
Provide remote technical assistance round-the-clock. In case of level 1 alert circumstance, provide field technical service, sending feedback to the cloud platform to optimize the algorithm.

Remote assistance 02
Visualized commissioning assistance and setting precaution strategy. Users will be informed via mobile app to take timely action when the alerts triggered.

Fault Alerts 03
By monitoring operating status of the equipment and failure algorithm, sending prescriptive info. about maintenance of key equipment, and the information can be sent to responsible person through APP, SMS.

Visualized Data 04
Core parameter graph, configuration diagram, fouling thickness, etc. Operating status of the equipment can be monitored real time.

Energy Consumption Assessment 05
Help user to set energy indicators by big data analysis and core algorithms, improving energy performance.

Intelligent Assessment 06
Heat transfer efficiency assessment; intelligent scheduling/regulation of network; online evaluation and prediction of cleaning cycle and cleaning effect.

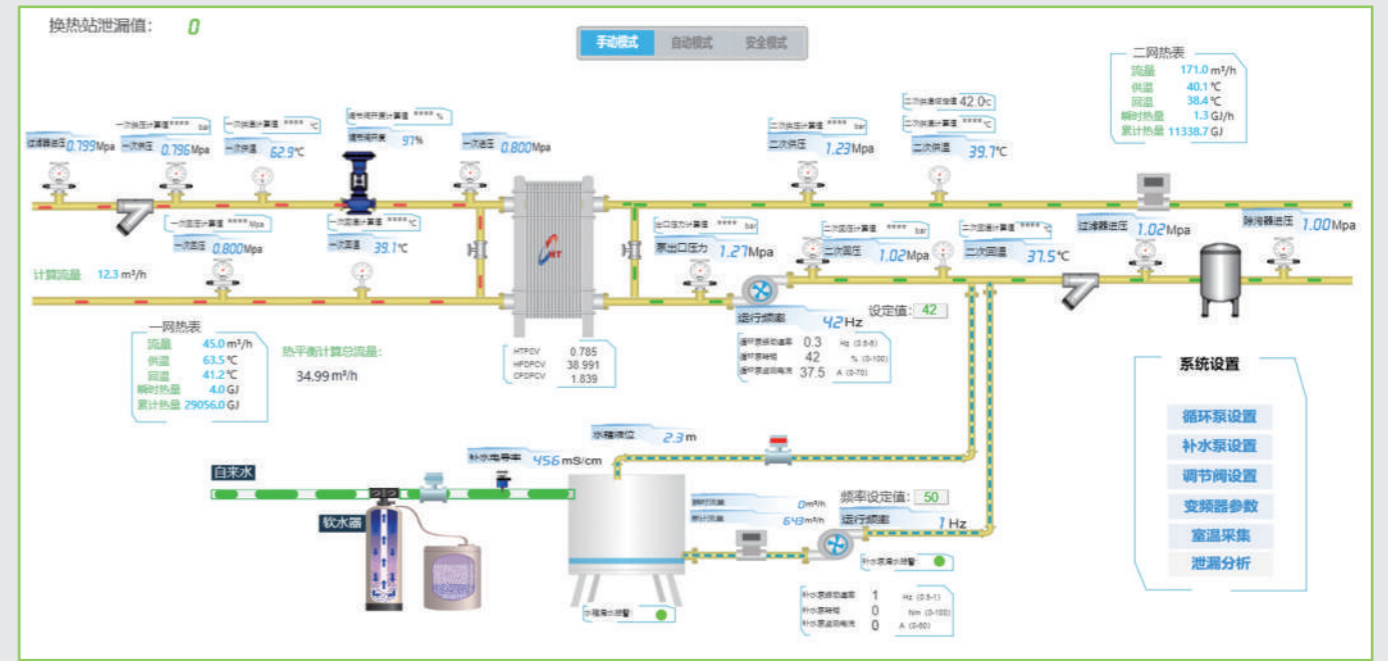

同时上海板换在冶金、石油化工、食品医药、船舶、电力等多个领域借助行业底层大数据可快速迭代行业解决方案，为设备安全运行、故障预警、节能降耗、维护提醒、清洗建议、备件更换、最佳工艺方案等提供专家指导。

Meanwhile, relying on big data of process industry such as metallurgy, petrochemical, food and pharmacy, marine, power plant, etc, SHPHE can iterate total solutions in time, and provide guidance for equipment safe operation, fault warning, energy saving and consumption reduction, maintenance reminding, cleaning suggestion, spare parts replacement and the best practice.

平台架构：
平台采用B/S架构设计，可实现可视化数据、资料信息的高效共享，能接入百万设备，响应时间毫秒级，物联网收发的数据会与传热平台进行算法交互，计算结果实时推送至用户侧或者边缘计算网关。

Platform architecture:
The platform adopts B/S structure, where visual data and information can be shared. The data received from IoT will interact with the heat transfer sizing platform, and the calculation will be sent to the user or computing gateway.

- 平台特点：**
1. 实际工况运行数据库；
 2. 热交换器核心预警算法；
 3. 实时推送最佳运行方案；
 4. 健康及清洗维护效果评估；
 5. 离线分析及驾驶舱集成。

- Platform features:**
1. operating data on site;
 2. Heat exchanger warning algorithm;
 3. Provide real time optimal operation scheme;
 4. Cleaning and maintenance effect evaluation;
 5. Offline data analysis.

Our Customers

部分业绩





Service Objective

服务宗旨

上海板换公司秉承“诚信为本 精益求精”的经营理念，始终坚持以先进的技术、优良的品质、持续的改进和周到的服务，满足或超越客户需求。公司在全球设立销售服务网络站点，以满足全世界客户的需求。

To be at the forefront of thermal exchange technology development, to offer problem solving solutions for the client's challenges, to offer the highest quality heat exchanger equipment to both the domestic and international marketplace, while always delivering value and reliability."

全球销售服务网络

Equipment To Both
The Domestic And
International

- | | | | |
|----------------|-----------|--------------|--------|
| B 韩国 | KOREA | H 土耳其 | TURKEY |
| C 印度 | INDIA | I 希腊 | GREECE |
| D 马来西亚 | MALAYSIA | J 俄罗斯 | RUSSIA |
| E 澳大利亚 | AUSTRALIA | K 法国 | FRANCE |
| F 阿联酋 | UAE | L 美国 | USA |
| G 巴尔干半岛 | BALKANS | M 巴西 | BRAZIL |